

CONVENTIONAL ZONE MODULE WITH SCI

VDOT-ZMU-SCI



Description

VDOT-ZMU-SCI Zone Module with Short Circuit Isolator is intended for use in addressable two wire systems, which can be connected with two-wire conventional detectors. The module monitors and transmits the status (normal, open, short, or alarm) of zone with the detectors to a control panel. The module is used for Class A (Style D & E) and Class B (Style B & C) operation.

Indicator

This module has three colored LED to indicate the status of Alarm, Polling and SCI.

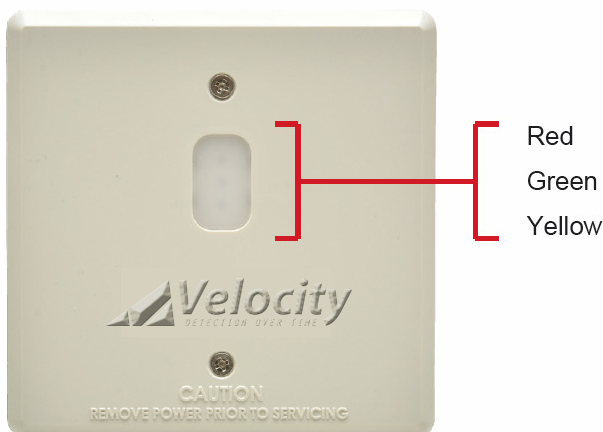

Alarm :Red
Polling:Green
SCI :Yellow

Features

- Loop powered conventional zone module.
- SCI function.
- Supports Class A and Class B wiring.
- SEMS screws for easy wiring.
- Status indicator LED.
- Analog communications.
- Address settable from 001 to 254 by a dedicated programmer.
- Low standby current (3mA).
- Mounts to optional 4-inch square junction box.

SCI Function

The module has a built-in short circuit isolator. SCI circuit prevents entire loop failure in the event of a short between L+ and L- on the loop.

Mounting

The module can be mounted directly to optional 4-inch square electrical box. The box must have a minimum depth of 2 1/8 inches.

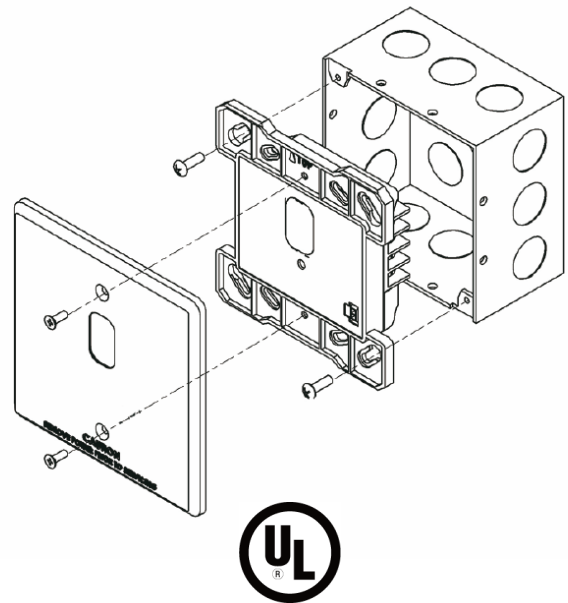

Wiring

Class B (Style B/C)

Detectors and EOL (20k ohm) are connected between A+ and A- in VDOT-ZMU-SCI.

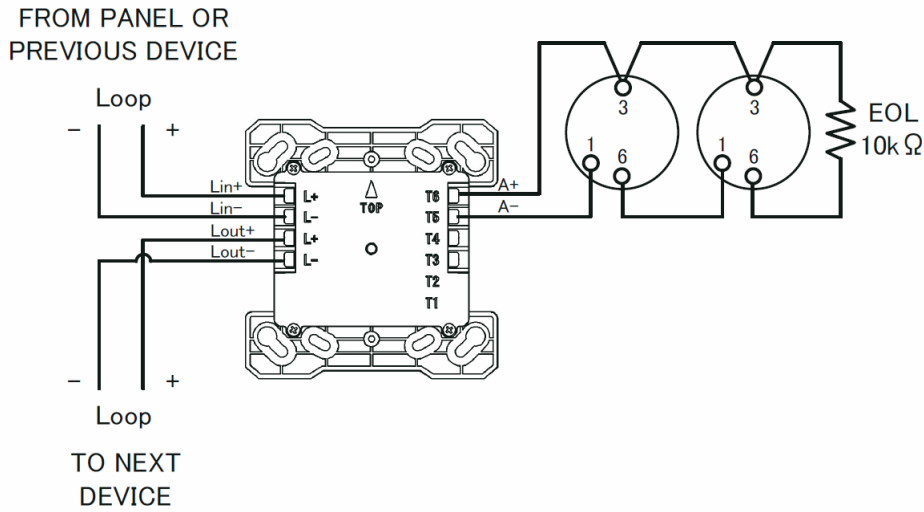

Class B (Style D/E)

Detectors are connected between (A+(B+_ and A-(B-) in VDOT-ZMU-SCI

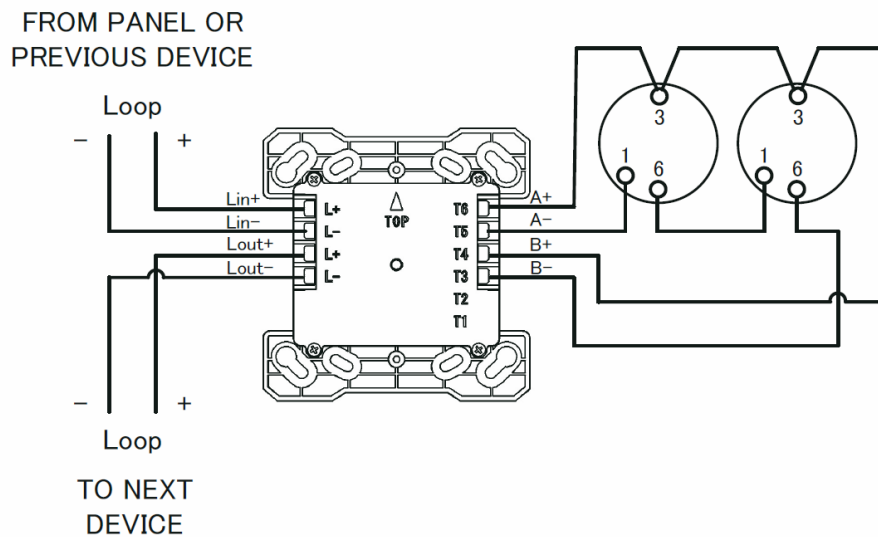

Subtype Setting

Subtype	Input Method	Open-Circuit Detection	Short-Circuit Detection	Class (Style)	Interrupt
1	Normally Open	Yes	No	Class B (Style B)	Disabled
2					Enabled
3				Class A (Style D)	Disabled
4					Enabled
5	Normally open	Yes	Yes	Class B (Style C)	Disabled
6					Enabled
7				Class A (Style E)	Disabled
8					Enabled

The operation mode of the module can be switched by setting Subtype as above. The sub-type can be set through control panel programming.

■ Specifications

Specifications	VDOT-ZMU-SCI
SLC Applied Voltage	Rated Range 20 to 38 VDC
SLC Current Consumption	Standby 2.6 mA Alarm 35.9 mA (max)
SLC Line Impedance	Up to 50 Ω
Number of IDC (Initiating Device Circuit)	1 x Class A or 1 x Class B
IDC Circuit Rating	12 to 18 VDC, 560 Ω , 32 mA (max)
IDC Line Impedance	Up to 50 Ω
EOL Device	RE-10 k (10 k Ω , 1/4 W), Class B only
SCI on Resistance	0.2 Ω (max)
SCI Fault Detection Threshold	10 V (min)
SCI Isolation Current	22 mA (max)
Visual Indicator (Status LED)	Polling LED (GREEN) Input LED (RED) SCI LED (YELLOW)
Ambient Installation Temperature	0 °C to 49 °C (32 °F to 120 °F)
Storage Temperature	-20 °C to 60 °C (-4 °F to 140 °F)
Max Relative Humidity	Up to 93 % RH, non-condensing
Environment	Indoor dry use only
Max Quantity Per Loop	127 Units
Terminal	Screw AWG12 to 22
Address Setting	VDOT-AD2 Address Programmer
Dimensions	H 124 mm x W 124 mm x D 34.5 mm (4.882" H x 4.882" W x 1.358" D) (Mount to a 4" square by 2 1/8" deep box)
Weight	Approximately 154 g
Standard	UL864

All specifications are subject to change without any notice.
For more information, contact with VELOCITY.



Zeta Alarms Limited
72-78 Morfa Road, Swansea
SA1 2EN
Tel: +44 1792 455 175 FAX: +44 1792 455 176

Distributed By