

Before Installation

Please read these instructions carefully and keep for future reference.

The information in this document is subject to change without notice. For updates please refer to our website.

CAUTION

Do not use the products outside the rated power supply voltage range specified in the Specifications. It may cause a fire or damage to equipment.

CAUTION

Do not disassemble, repair, or modify the products. It may cause a fire or electric shock.

CAUTION

Make sure to turn the power off before commencing any wiring work. Otherwise it may cause electric shock or damage to equipment.

Note: Follow the requirements for the installation of the products in accordance with the Specifications. Otherwise it may cause malfunction.

Note: Do not install the product in any location where oil, dust, iron powder, chemicals, or hydrogen sulphide may occur or affect the product. It may cause damage to equipment.

Section 1 – INTRODUCTION

VDOT-STB-RL is a detector base with relay output for use with Velocity MMP Control Panels, which is designed for use with an addressable detector. When a detector is in alarm condition, the base receives a control signal from the detector, which has the relay operate. The rating of contact is DC30V/1A.

Section 2 - TERMINALS

VDOT-STB-RL base is supplied with 3 terminals as standard, along with a relay output terminal block of C form contact.

The terminals of VDOT-STB-RL base are configured as follows:

- Terminal 1 = SLC positive
- Terminal 6 = SLC negative
- Terminal 3 = No connection
- Relay terminal block with N/O, N/C, and COM

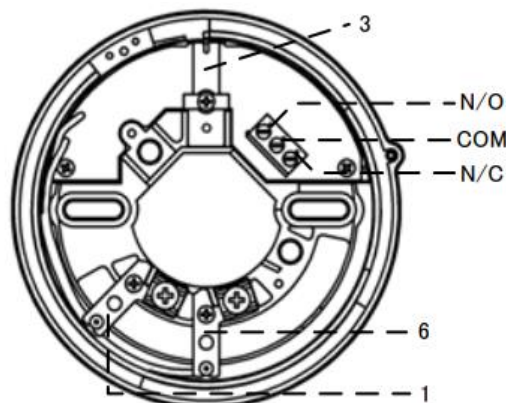

Figure 1: Position of terminals

Section 3 – Dimensions

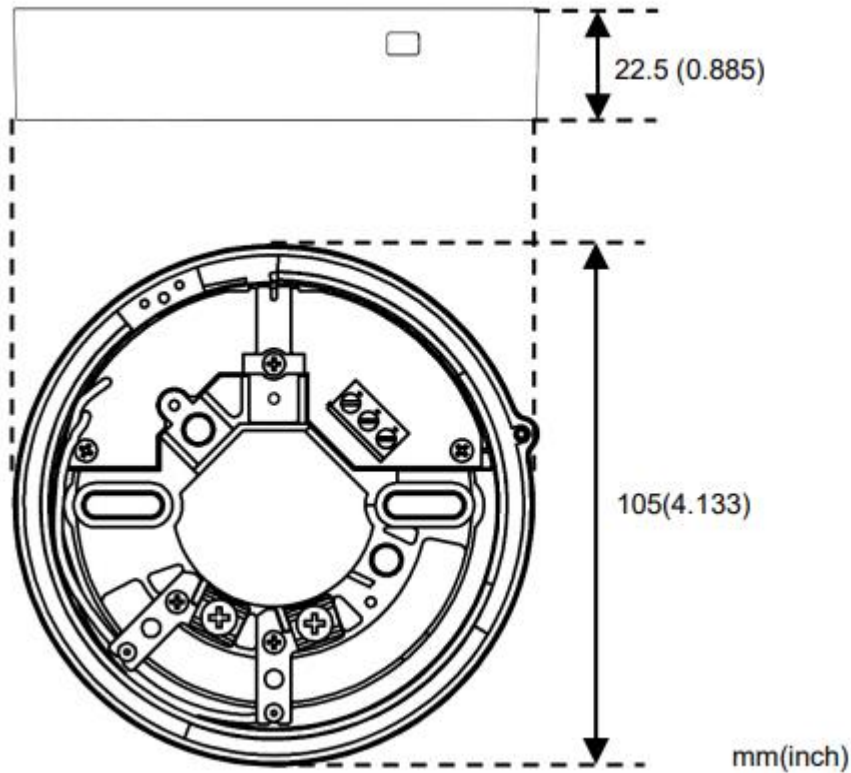

Figure 2: Dimension of VDOT-STB-RL

Section 4 – DETECTOR MODELS

VDOT-STB-RL are available for use with the VDOT series detectors.

It is important to use the correct detector for each application.

The standard range of detectors available is as follows:

Model	Description
VDOT-PY	Analog addressable photoelectric smoke detector
VDOT-PYH	Analog addressable combination photoelectric smoke and heat detector 57°C (135°F) with 8.3°C (15°F) rate of rise
VDOT-H2	Analog addressable heat detector 57°C (135°F) with 8.3°C (15°F) rate of rise
VDOT-DPH	H Analog addressable combination photoelectric smoke (dual wave length) and heat detector 57°C (135°F) with 8.3°C (15°F) rate of rise

Optional accessory

VDOT-ADP adapter: Use this adapter when VDOT-STB-RL is installed with a 4" square electrical box or 4" octagonal electrical box. (Refer to "VDOT-ADP Instruction Manual" for details.)

Section 5 – INSTALLATION

The product must be installed in accordance with the applicable NFPA standards, local codes and jurisdictional authorities. Failure to follow these instructions may result in failure of the detector to report an alarm condition.

Note: ZETA ALARM SYSTEMS is not responsible for the product which is improperly installed, maintained and tested.

Note: Use the VDOT-ADP adapter for a 4" square electrical box or 4" octagonal electrical box. VDOT-ADP adaptor is not used for a 3-1/2" octagonal electrical box.

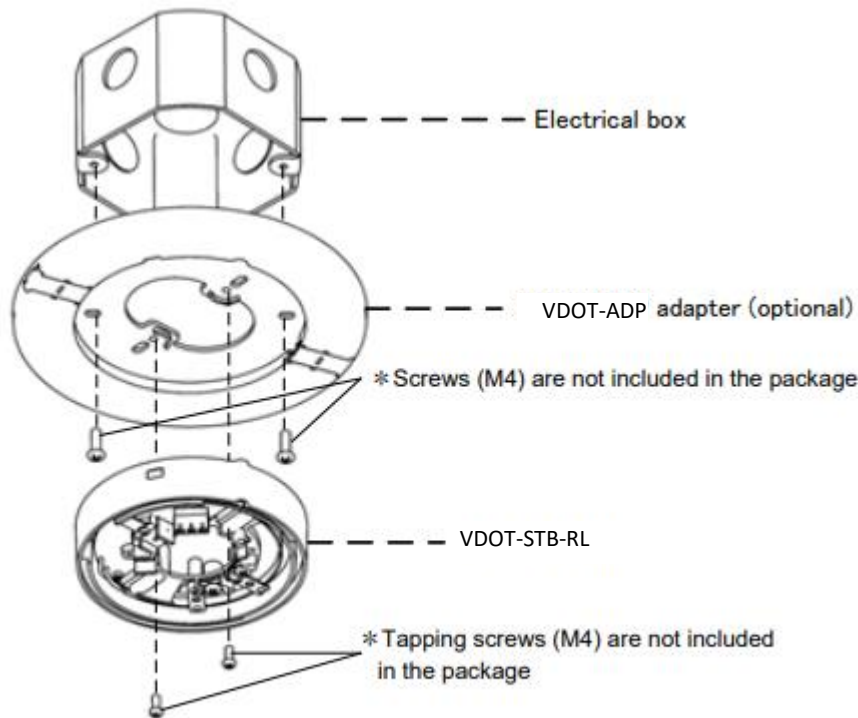

Figure 3: Installation to an electrical box

Section 6 – CONNECTIONS

Install wiring in accordance with Figure 4 in this document.

All wiring must conform to applicable local codes, ordinances and regulations.

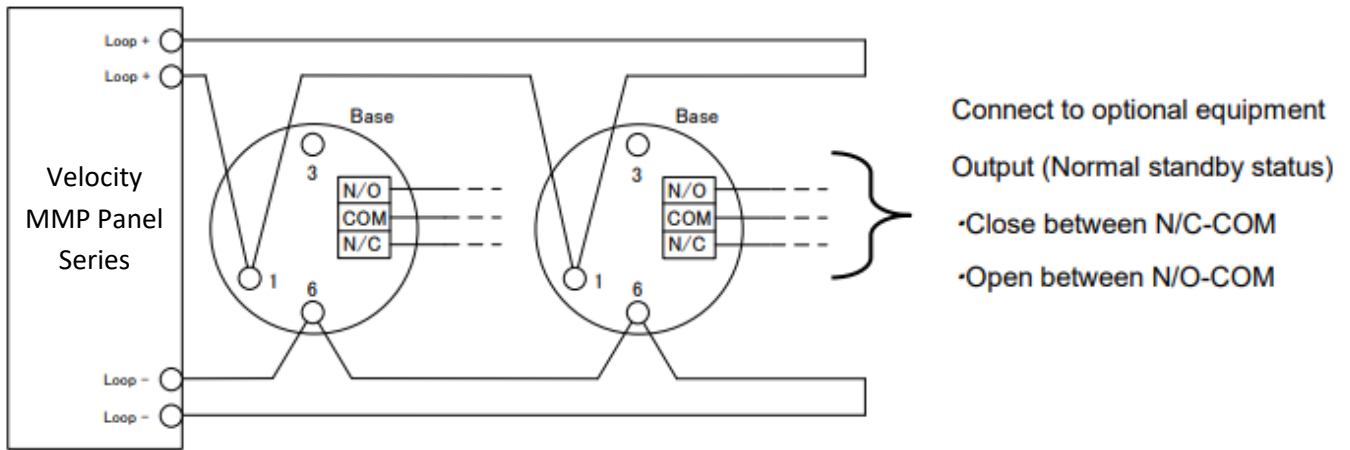

Figure 4: Connection to a control panel Velocity MMP series

CAUTION

Use cable AWG12-20 for SLC terminals, and cable AWG14-22 for relay terminals. Do not connect different gauge cables at one terminal in order to prevent loosening.

CAUTION

Do not connect cables in reverse polarity. Failure to connect the polarity correctly could result in damage to other equipment.

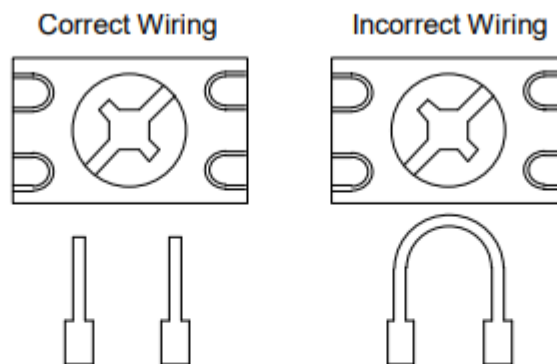

Figure 5: Connection to terminals

CAUTION

For system monitoring - for terminals 1 and 6, do not use looped wire under terminals. Break wire run to provide monitoring of connections.

Before installing the product check the continuity, polarity and insulation resistance of all wiring. Check that siting is in accordance with the site system drawings and conforms to all applicable local codes such as NFPA 72.

In normal use, the VDOT-STB-RL base will be installed at ceiling level. Pass the field wiring through the cable hole in the center and from the rear of the base. Hold and affix the base to the ceiling or electrical box with screws via the base mounting holes. Connect the field wiring to the base terminals, as detailed in Section 5 and 6, making sure the wiring does not obstruct fitting of the detector head.

Fit the detector head by inserting it into the base and turning clockwise until the notch in the detector rim aligns with base locking screws. To avoid unauthorized de-installation, turn the locking screw counterclockwise until the screw comes to about 4mm(3/16") from the rim of the base, as shown in Figure 6. The OMNIVIEW™ 360° indicator permits visibility from any angle.

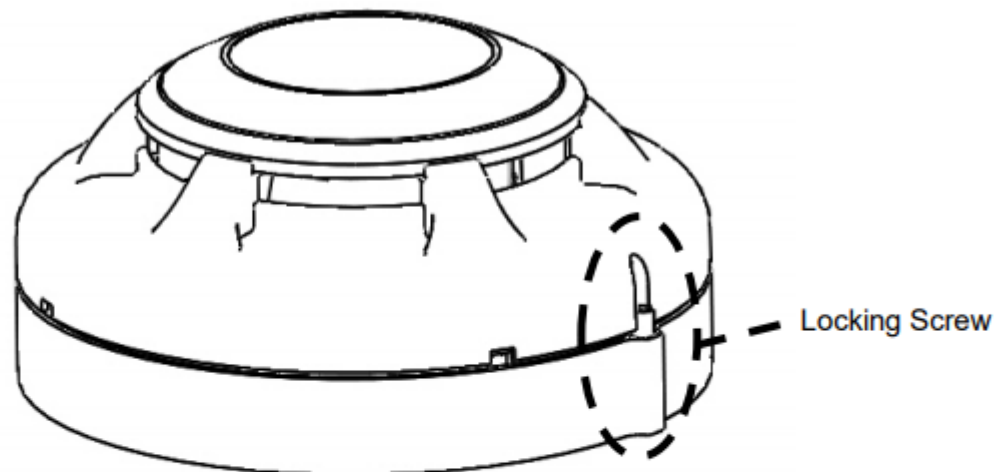

Figure 6: Position of locking screw

CAUTION

Smoke and heat detectors are not to be used with detector guards unless the combination has been evaluated and found suitable for that purpose.

Section 7 – Maintenance

Maintenance

The VDOT-STB-RL is a high quality product engineered for reliability. In order to obtain optimum performance, periodic maintenance is required, at least in accordance with NFPA 72 chapter 14 “Inspection, Testing and Maintenance”.

Routine Inspection:

Ensure the detector head and the base are secure and undamaged.

Operation Test:

The purpose of the Operational Test is to confirm the product’s correct operation.

1) When carrying out site testing of the product, the control panel shall be set to “one-man-walk test mode” prior to the test.

- 2) Take any necessary precautions to limit the sounding of the alarm sounders/bells and any fire service summoning device.
- 3) Operate the detector in accordance with each detector's instruction manual as specified in Section 4. Check that the LED indicator on the detector illuminates. When the detector goes into an alarm status, confirm that the output relay of the product is in operation (close between N/O and COM, open between N/C and COM).

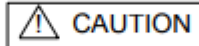

Please note that the output relay operates if the detector is in operation even though in the "one-man-walk test mode". Take appropriate measures depending on the situation in the field.

Note: If the test cannot be carried out by operating the detector, remove the detector and short between terminal 3 and 6 to check the relay switches.

- 4) After the detector has given the alarm condition, the detector is automatically reset by control panel. It may be necessary to allow a short time to elapse before resetting the detector. Confirm that the output relay goes back to the initial status (open between N/O and COM, close between N/C and COM) after the detector is reset.

Note: For detector testing and cleaning information, refer to each detector's instruction manual as specified in Section 4.

Section 8 – SPECIFICATION

SLC Applied Voltage	Rated Range 20VDC to 38VDC
SLC Current Consumption	Standby 24µA Alarm/Activated 110µA
SLC Line impedance	Up to 50ohms (Refer to * below)
RELAY	Switching capacity DC 30V/1A resistive
UL Ambient Installation Temperature	0°C(32°F) to 38°C(100°F)
Operating Temperature	-10°C(14°F) to 55°C(131°F)
Storage Temperature	-20°C(-4°F) to 60°C(140°F)
Max Relative Humidity	Up to 95% RH, non-condensing
Environment	Indoor dry use only
Terminal	Terminal for SLC: AWG12 to 20 Terminal for Relay: AWG14 to 22
Dimensions	φ105 mm x 22.5 mm H (φ4.133" x 0.885" H) (Mount to a 3-1/2" octagonal box)
Weight	Approximately 79g (2.8 ounces)
Standard	UL268 and UL521

* Refer to the Installation and Operation Manual of Control Panel Velocity MMP series to determine correct loop load and maximum loop resistance for devices connected to each loop.