

Description

The 3-Relay (3-Rel) Module provides outputs from the ZT-MNS-100 to be used to signal other system devices.

Two are set as Active and Trouble outputs, with one special purpose output.

The Form-C relay dry contacts allow Normally Open (NO) or Normally Closed (NC) operation, rated for 24VDC nominal, 30VDC and 3Amps maximum.

Specifications

Input:

Voltage: Regulated 24 VDC
 Current: 0.07 Amps Active, 0.03A standby
 Data: I₂C Bus

Output:

Contacts: Form-C Dry contacts (N.O. / N.C.),
 30VDC, 3A
 Connectors: Removable headers, accept 18 to 12AWG
 Board Size: Small Accessory Module; 2-3/4" x 3-1/2"
 Mounts in basic or expanded cabinet

System Installation

The ZT-MNS-3-REL Relay Module mounts on dedicated standoffs in either the expanded or basic cabinet. Mount the board with the output connections (J2) so the field wires can route to access knockouts.

There are 4 mounting holes in the board. Using the 6-32x3/8" screws; attach the board into the box securely.

The pre-assembled Power-Data Cable # 590-0510 attaches the module to the Main Controller/Amp.

Red & Black connect to J32 (24V-Out), and Blue & White connect to J25 (I₂C)-Bus on the Main Board.

If there are connections already to the J32, and/or J25; then cut the cable to length, and connect these wires to another optional module's connections that has screw terminals, following the same color code.

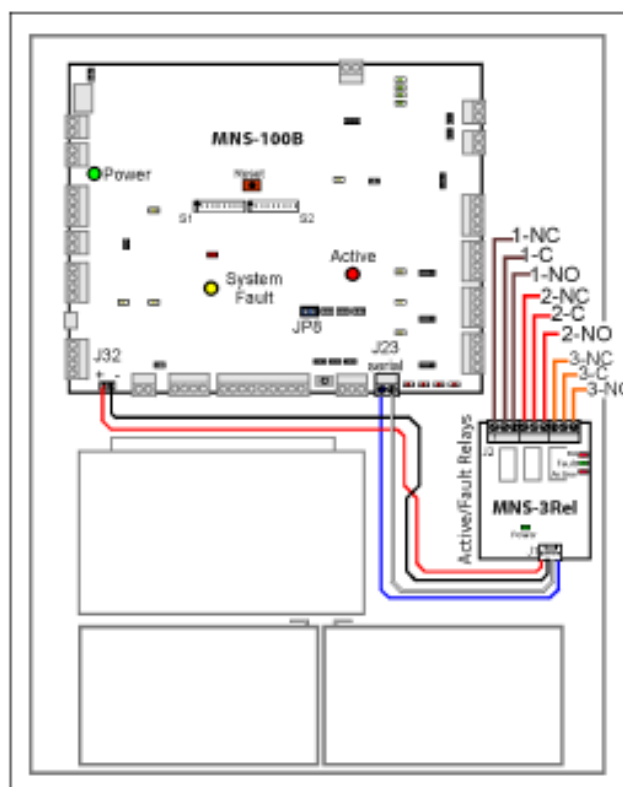

To enable the ZT-MNS-3-REL module the JP8 Jumper must be installed on the main Controller/Amp board.



Connections

There are two connectors on the 3-Relay board. **J1** connects to the main controller/amp board, and **J2** has the relay outputs. The drawings below show the orientation of the connectors and pins if the board was held so the writing on the board is readable. On the back of the board under each connector; Pin one (1) is marked with a square pad while the other pins have a round pad.

J1: Input

24VDC Regulated power from system
Pin 1 +, Pin 2 -

Serial Internal system serial bus,
Pin 3 SDA, Pin 4 SCL

J2: Outputs:

Relay #1 System Active
Pin1 NC, Pin 2 Common, Pin 3 NO

Relay #2 System Trouble (Fault)
Pin4 NC, Pin 5 Common, Pin 5 NO

Note: The Trouble Relay is normally held on, and released upon Fault. So the 2-NO, and 2-NC connections are functionally reversed.

Relay #3 (system special purpose, normally unassigned)
Pin7 NC, Pin 8 Common, Pin 9 NO

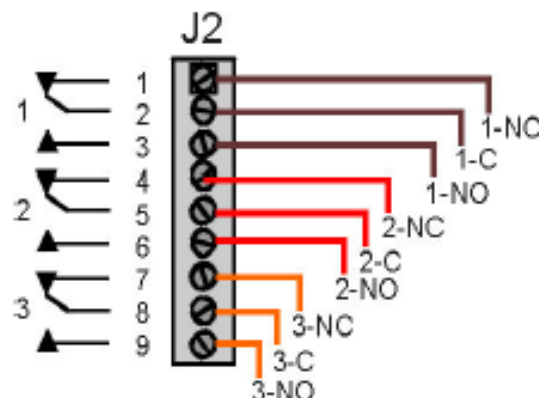
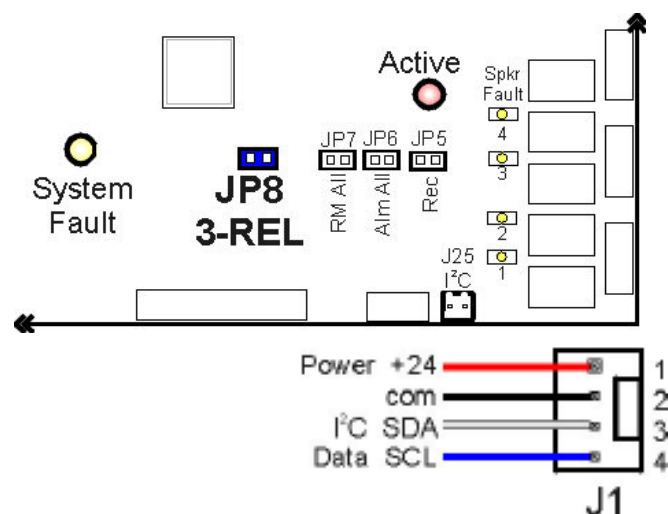

MNS-3-Relay Board Layout

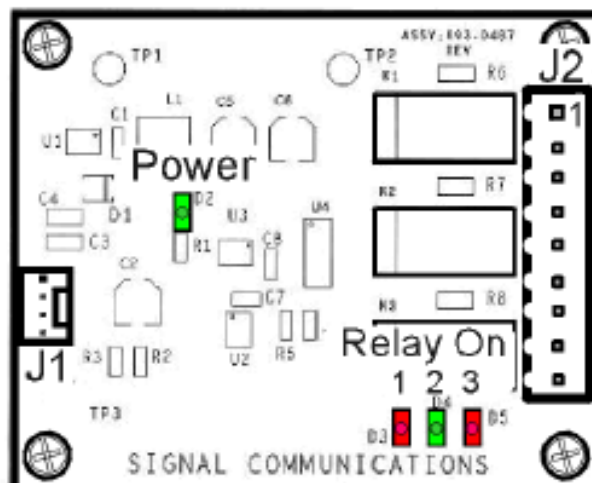

Indicators

The 3-Relay Board includes 4 LED indicators;

- a Green LED for Power indication
- three Relay-On active LEDs
Red for Relays 1 and 3
Green for Relay 2

Relay 2 is the Trouble or Fault Relay and is normally activated and is released during any system Fault condition.

This causes the LED for Relay #2 to be illuminated normally, and off during the Fault.

The NC and NO contacts of the Trouble relay would also be functionally reversed,

i.e. The Common (C) would be contacting the Normally Open (NO) during the 'System Normal' condition, and would open during a Fault.



Limited Warranty

Velocity Detection over Time Zeta Alarms Ltd declares that this product is free from defects in material and workmanship and it will repair or replace any product or part thereof which proves to be defective in workmanship or material for a period of twelve (12) months from the date of purchase but not to exceed eighteen (18) months from the date of manufacture.

Please contact Velocity Detection over Time Zeta Alarms Ltd directly for a return merchandise authorization (RMA) number before returning goods under warranty. Shipment must be prepaid and Velocity Detection over Time Zeta Alarms Ltd will repair or replace the product if the failure was caused by a manufacturing defect.